

NME954 & FME1204 SERVICE PARTS

This parts list contains the service parts and wiring diagrams for this model. Check the model number in question to be sure that it is applicable to this parts list.

Note that these machines have been manufactured in both 50 and 60 cycle. 60 Hz model numbers end in -3 or -32. 50 Hz model numbers end in -6.

Another change was to the water cooled condensers. Model numbers ending in A have a different water cooled condenser than the current model.

TABLE OF CONTENTS

Cabinet	2
Air Cooled Refrigeration	3
Water Cooled Refrigeration	4
Water System	5
Gearmotor	6
NME Evaporator	7
FME Evaporator	8
Control Box	9
Wiring Diagrams	10

NME954 & FME1204 SERVICE PARTS

Cabinet Assembly

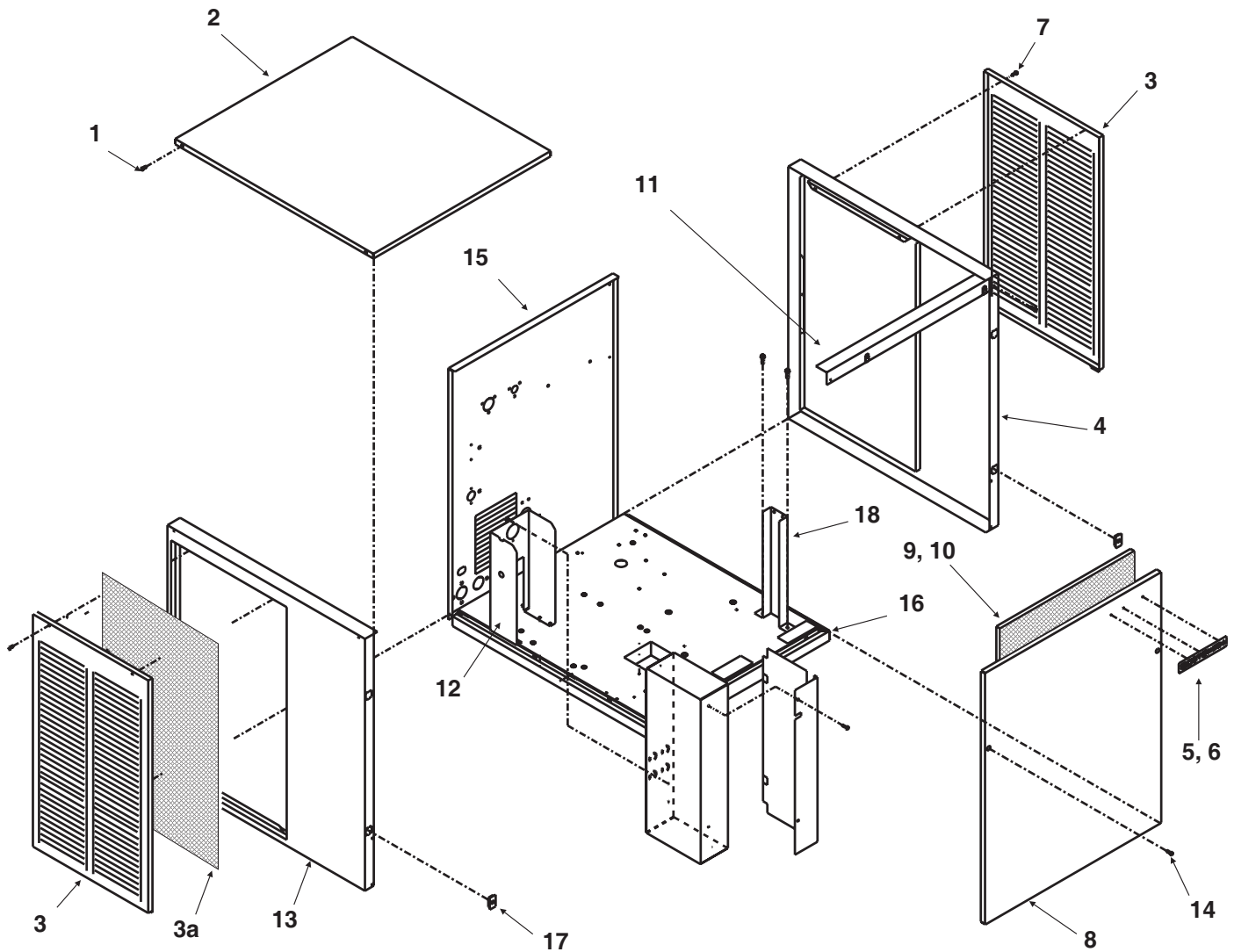

ITEM NUMBER	PART NUMBER	DESCRIPTION	ITEM NUMBER	PART NUMBER	DESCRIPTION
1	03-1531-01	Screw	9	02-2976-01	Filter Assembly for louvered front panel
2	A33256-002	Top Panel, S.S.	10	03-1660-01	Filter clip
3	A34038-002	Service Panel, non-louvered	11	A34348-001	Ft. brace
	A33946-032	Service panel, louvered	12	A34039-001	Control Box Support
3a	A32975-001	Air filter media, for louvered service panel. Same on other side	13	A32435-002	Left Side Panel, S.S.
4	A33292-002	Right Side Panel, S.S.	14	03-1419-22	Screw
5	03-0271-00	Speed Clip	15	Water Cooled only:	
6	15-0808-01	Emblem, grey		A35924-002	Rear panel, stainless
7	03-1404-12	Screw	16.	A35890-001	Base
8	A33255-002	Front Panel, louvered	17	02-0836-00	Catch
	A39048-001	Front panel, non-louvered		15-0411-00	Strike (on front panel)
			18	A36078-001	Reservoir bracket

NME954 & FME1204 SERVICE PARTS

Air Cooled Refrigeration

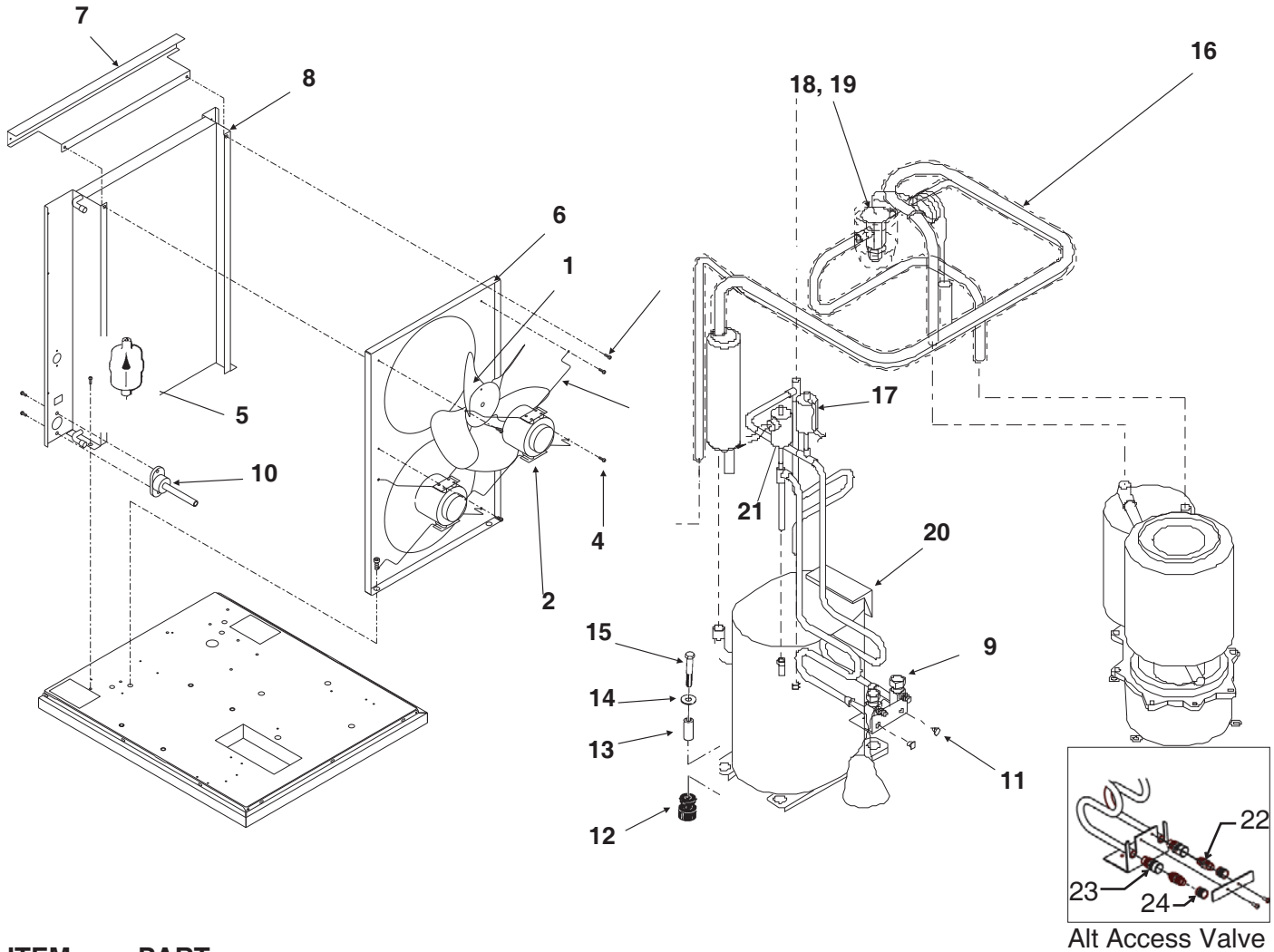

ITEM NUMBER	PART NUMBER	DESCRIPTION
1	18-3815-01	Fan Blade
2	12-1576-02	Fan Motor
3	02-2378-01	Fan Bracket
4	03-1404-12	Screw
5	02-3319-02	Dryer
6	A33231-015	Fan Shroud
7	A35582-002	Fan shroud cover, stainless
8	18-8717-01	Condenser
9	16-0832-20	Access valve
9a	16-0832-02	Stem cap
9b	16-0832-03	Core cap
10	A34045-001	Drain casting
11	03-1645-01	Screw
12	18-2200-28	Grommet
13	18-2300-27	Sleeve
14	03-1407-07	Washer
15	03-1405-20	Cap Screw

ITEM NUMBER	PART NUMBER	DESCRIPTION
16	A36496-001	Suction Line
17	11-0501-22	Hi Pressure Cut Out
18	A32961-020	Insulation Kit (3 piece)
19	11-0488-21	Thermo Expansion Valve
20	18-8768-22	Compressor 208-230/60/1 Overload for above is internal
	18-8768-24	Compressor 200-230/60/3 Overload for above is internal
	18-8772-26	Compressor 220-240/50/1
	18-8772-21	Overload for above
21	11-0502-21	Low pressure cut out switch
22	16-1139-01	Core
23	16-1137-01	Access valve body
24	16-1140-01	Cap

NME954 & FME1204 SERVICE PARTS

Water Cooled Refrigeration

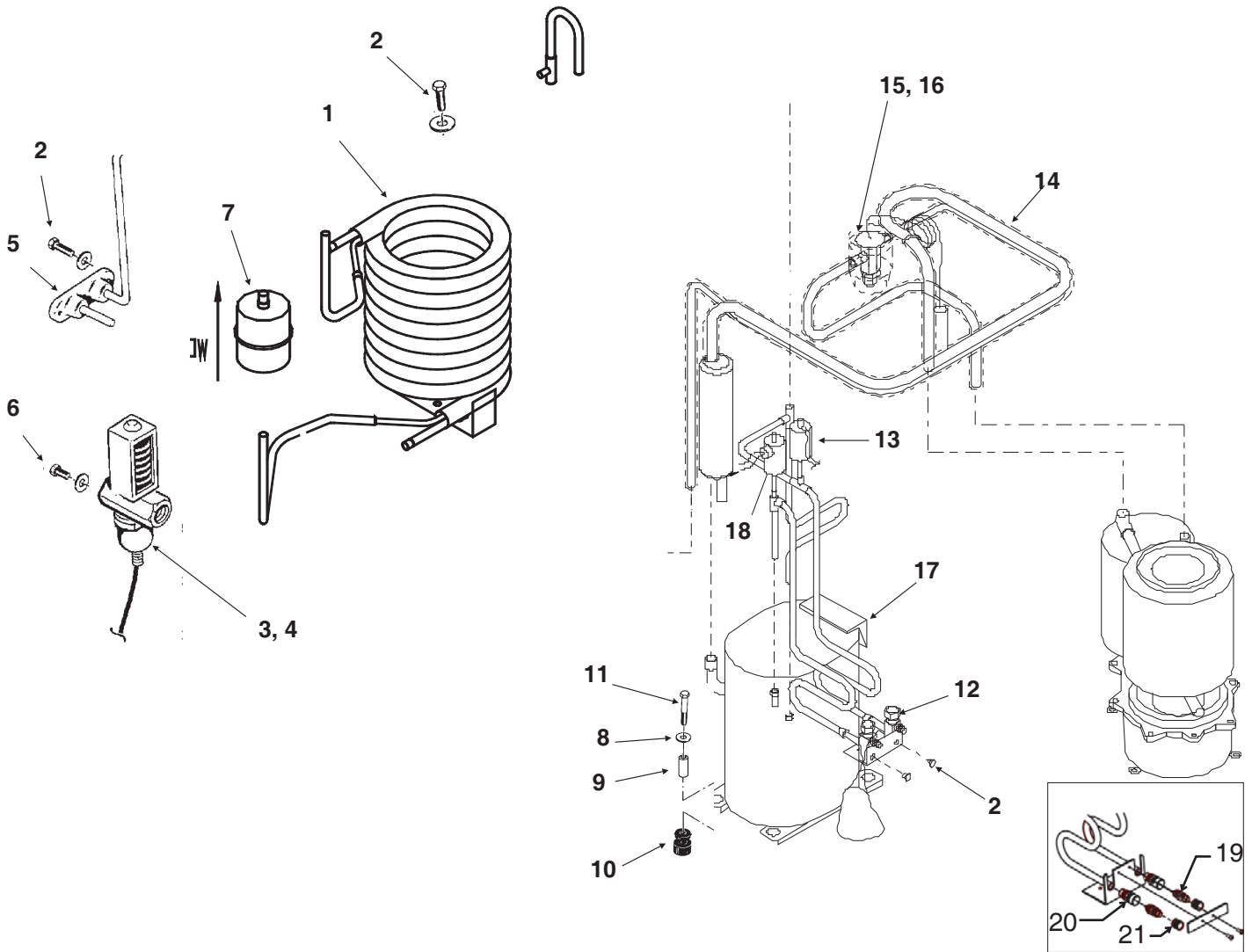

ITEM NUMBER	PART NUMBER	DESCRIPTION
1	18-8718-25	Condenser for A series
	18-8873-21	Condenser for B series
2	03-1645-01	Screw
3	11-0478-.01	Water Reg. Valve
4	16-0401-02	Elbow (not shown)
5	A34044-001	Drain Assembly
6	03-1403-14	Screw
7	02-3319-02	Dryer
8	03-1407-07	Washer
9	18-2200-27	Sleeve
10	18-2200-28	Grommet
11	03-1405-20	Screw
12	16-0832-20	Access Valve Complete
12a	16-0832-02	Stem cap
12b	16-0832-03	Core cap
13	11-0501-22	Hi Pressure Cut Out
14	A36496-001	Suction Line
15	A32961-020	Insulation Kit (3 piece)
16	11-0488-21	Thermo Expansion Valve
17	18-8768-22	Compressor 208-230/60/1
		Overload for above is internal
	18-8768-24	Compressor 200-230/60/3
		Overload for above is internal
	18-8772-26	Compressor 220-240/50/1
	18-8772-21	Overload for above
18	11-0502-21	Low pressure cut out switch
19	16-1139-01	Core
20	16-1137-01	Access valve body
21	16-1140-01	Cap

NME954 & FME1204 SERVICE PARTS Water System

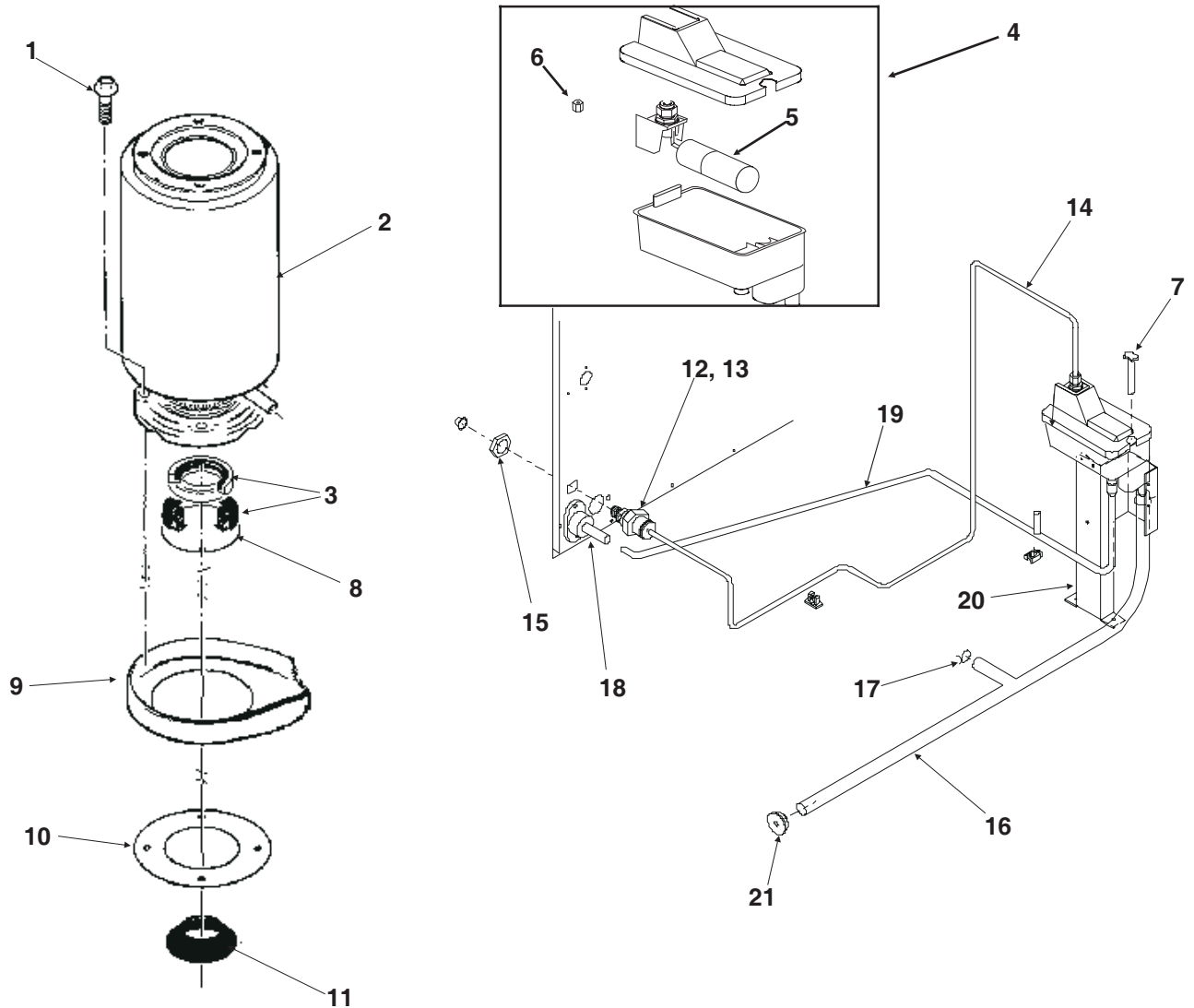

ITEM NUMBER	PART NUMBER	DESCRIPTION
1	03-1420-03	Cap Screw
2	A32890-020	Evaporator
3	02-0929-23	Water Seal
4	02-3266-20	Reservoir & valve
5	02-3266-21	Float valve
6	02-3266-03	Plunger/seat
7	12-2760-21	Water Level Sensor
8	A32777-001	Retaining Ring for Seal
9	02-3837-01	Drip Pan
10	13-0704-00	Gasket
11	13-0868-01	Water Shed

ITEM NUMBER	PART NUMBER	DESCRIPTION
15	03-1394-01	Pal nut
16	A36154-001	Evap. water inlet tube
17	02-1338-00	Hose clamp
18	02-3692-02	Drain fitting
19	02-3826-01	Res. overflow hose
20	A36078-002	Reservoir bracket
21	13-0840-01	Rubber cap

NME954 & FME1204 SERVICE PARTS

Gearmotor

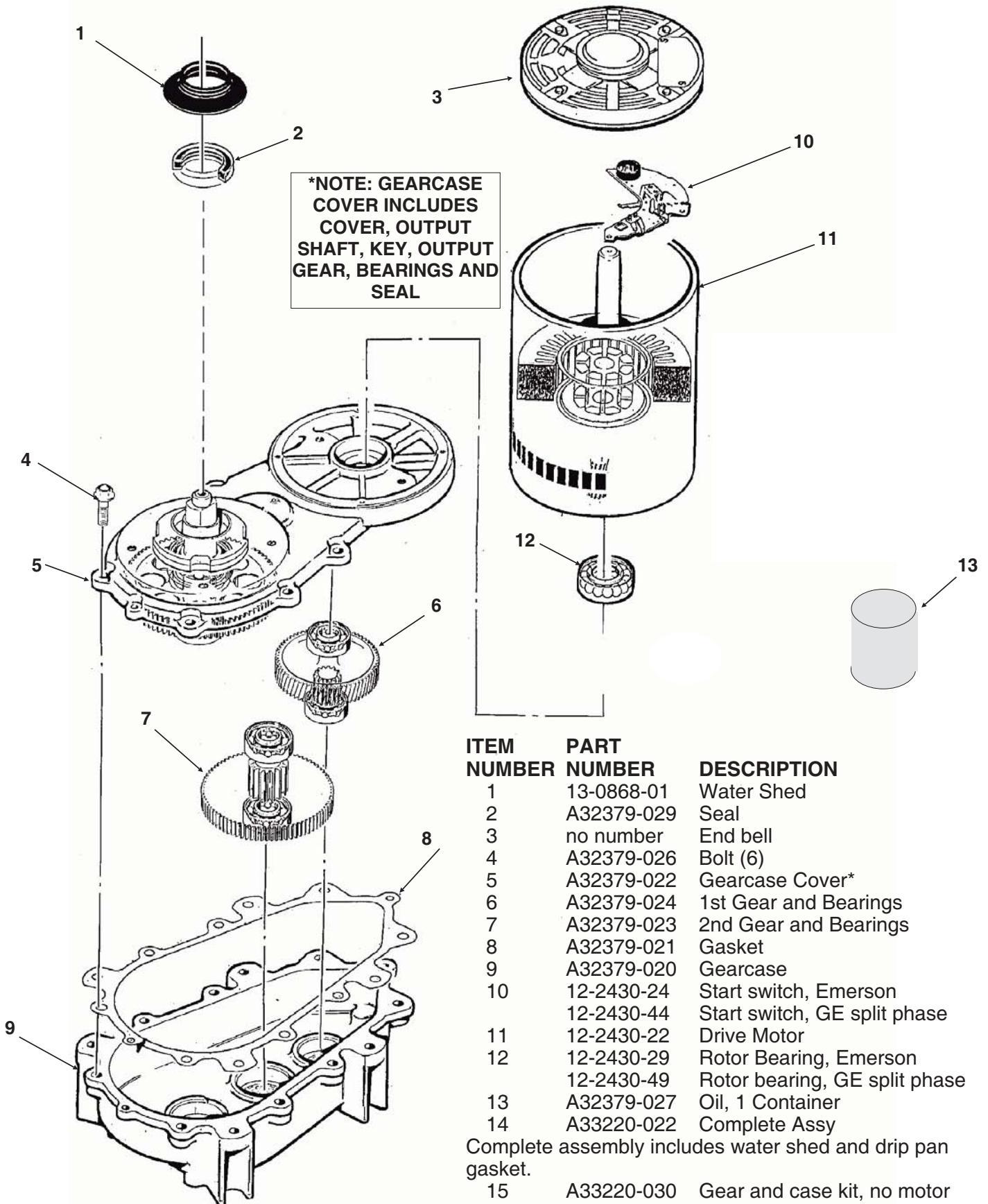

NME954 & FME1204 SERVICE PARTS

NME Evaporator

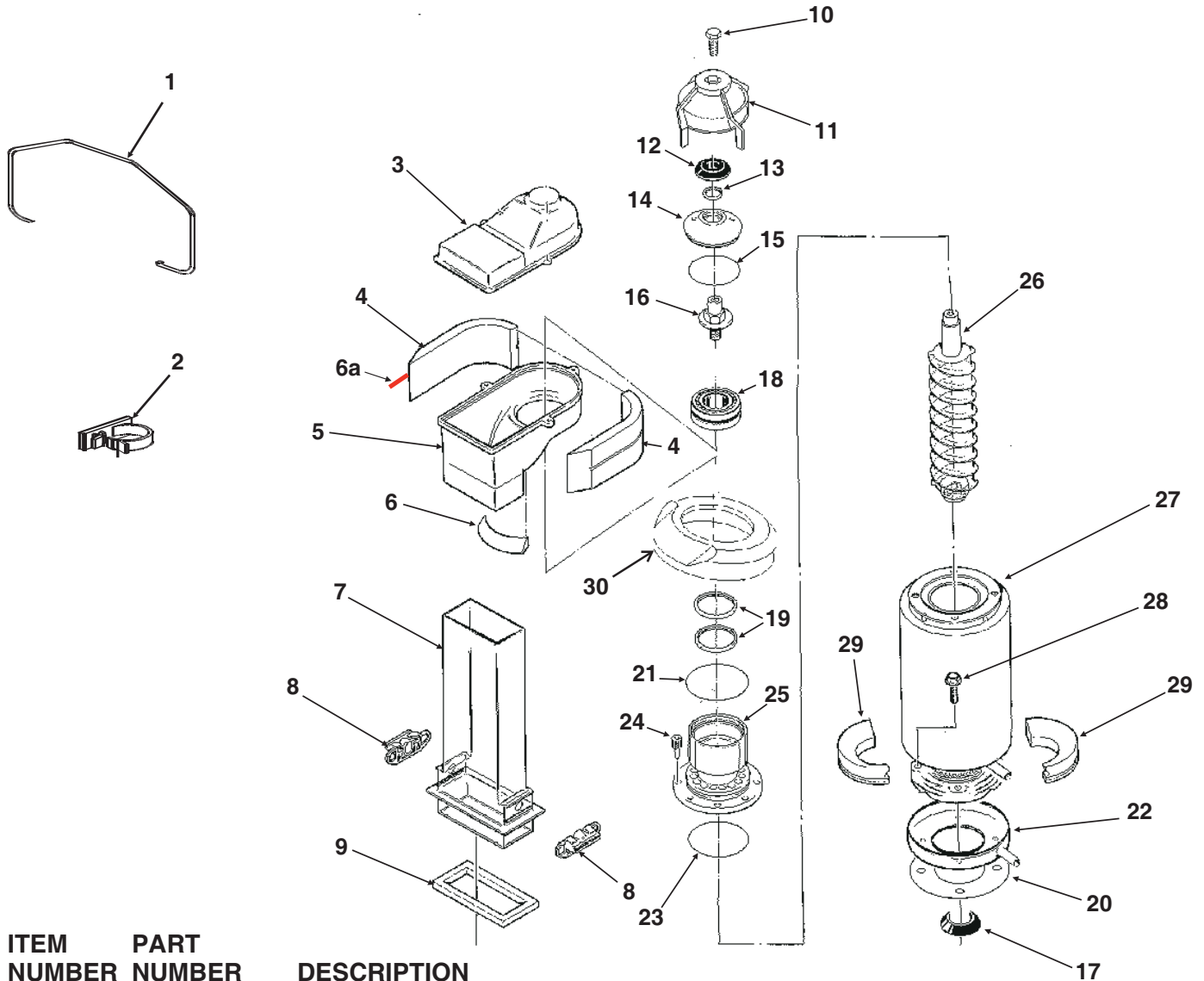

ITEM NUMBER	PART NUMBER	DESCRIPTION
1.	A34969-001	Bail clip
2.	02-3268-01	Drain tube holder
3.	02-2930-04	Ice Chute Cover
4.	A32963-001*	Insulation Top (half)
5.	02-3841-01*	Ice Chute Body, includes insulation, repl item 4
6.	A33102-001*	Insulation Collar Inside
6a	A35419-020*	Strap kit
7.	02-2929-04	Ice Chute Lower
8.	A37708-021	Bin Controls Kit. (set of 2)
9.	A32930-001	Chute Gasket
10.	03-1405-52	Hex Cap Screw
11.	02-3001-01	Ice Sweep
12.	13-0871-01	Water Shed
13.	02-2978-01	Lip Seal
14.	02-3128-20	Breaker Cover
15.	13-0617-52	O-Ring
16.	08-0660-01	Auger Stud & washer
17.	13-0868-01	Water Shed
18.	A34559-020	Bearing
19.	02-2977-01	Lip Seal
20.	13-0704-00	Drip Pan Gasket
21.	13-0617-54	O-Ring
22.	02-3837-01	Drip Pan
23.	13-0617-45	O-Ring
24.	03-1544-08	Soc. Head Screw
25.	A32900-020	Breaker (includes 18 & 19)
26.	A38071-022	Auger
27.	A32890-020	Evaporator
28.	03-1420-03	Cap Screw
29.	A32962-001	Insulation Bot. (half)
30.	13-0929-02	Insulation donut*

* Insulation changed Oct. 2000. Item 4, 6 and 6a no longer used. Item 5 changed. Item 30 added.

NME954 & FME1204 SERVICE PARTS

FME Evaporator

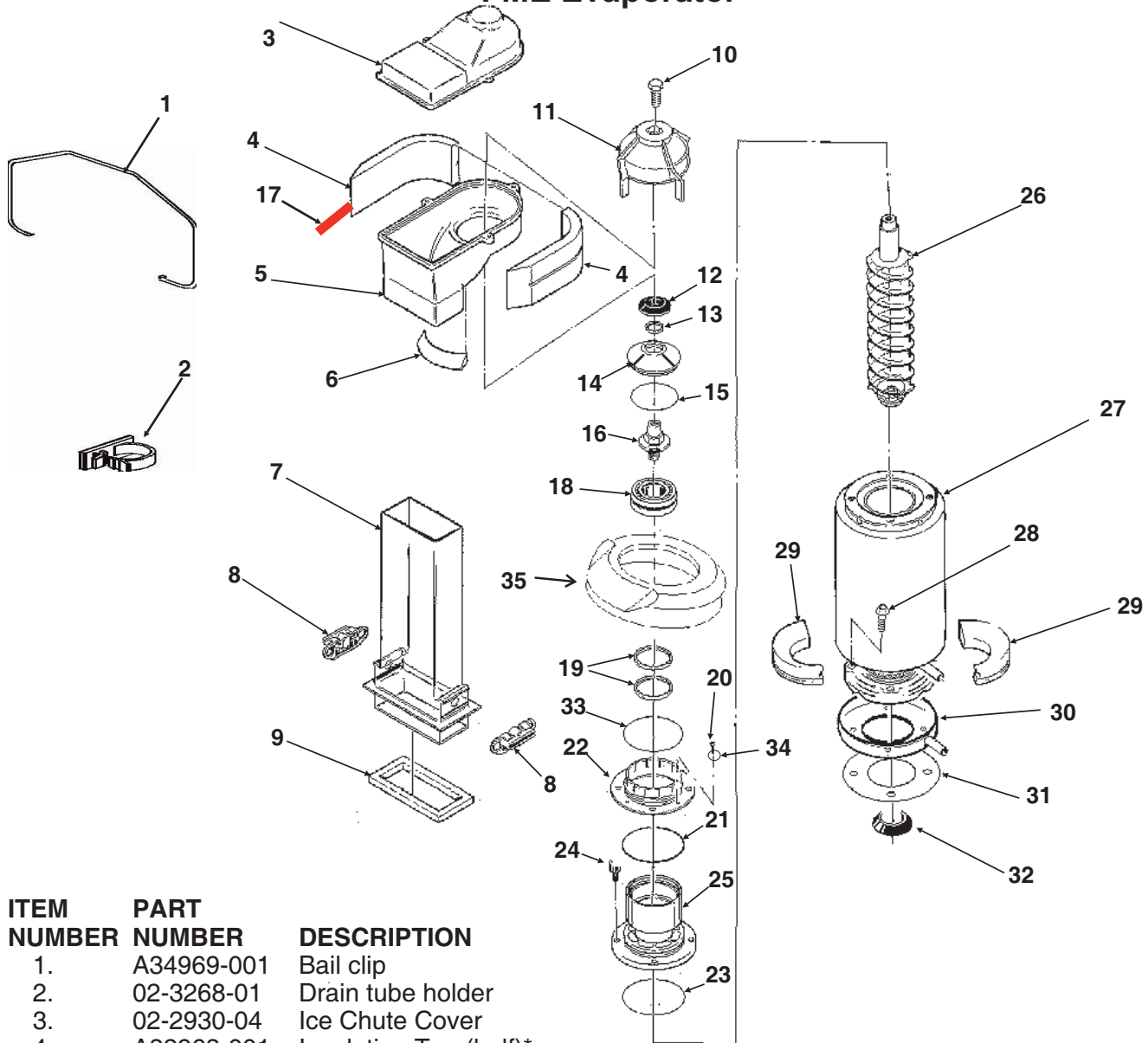

ITEM NUMBER	PART NUMBER	DESCRIPTION
1.	A34969-001	Bail clip
2.	02-3268-01	Drain tube holder
3.	02-2930-04	Ice Chute Cover
4.	A32963-001	Insulation Top (half)*
5.	02-3841-01	Ice Chute Body, with foam, replaces item 4*
6.	A33102-001	Insulation Collar Inside*
7.	02-2929-04	Ice Chute Lower
8.	A37708-021	Bin Controls Assy. (set of 2)
9.	A32930-001	Chute Gasket
10.	03-1405-52	Hex Cap Screw
11.	02-3001-01	Ice Sweep
12.	13-0871-01	Water Shed
13.	02-2978-01	Lip Seal
14.	02-3128-20	Breaker Cover
15.	13-0617-54	O-Ring
16.	08-0660-21	Auger Stud, thrust Washer
17.	A35419-020	Strap kit*
18.	A34559-020	Bearing
19.	02-2977-01	Lip Seal
20.	03-1405-27	Screw
21.	13-0617-52	O-Ring
22.	02-2916-01	Slotted Collar
23.	13-0617-45	O-Ring
24.	03-1544-08	Soc. Head Screw
25.	A34505-020	Breaker (Divider) (includes 18 & 19)
26.	A38071-022	Auger
27.	A32890-020	Evaporator
28.	03-1420-03	Cap Screw
29.	A32962-001	Insulation Bot. (half)
30.	02-3837-01	Drip Pan
31.	13-0704-00	Drip Pan Gasket
32.	13-0868-01	Water Shed
33.	13-0617-49	O-Ring
34.	03-1408-36	Washer
35.	13-0929-01	Insulation donut*

* Insulation changed Oct 2000. Items 4, 6 and 17 no longer used. Item 5 changed. Item 35 added.

NME954 & FME1204 SERVICE PARTS

Control Box

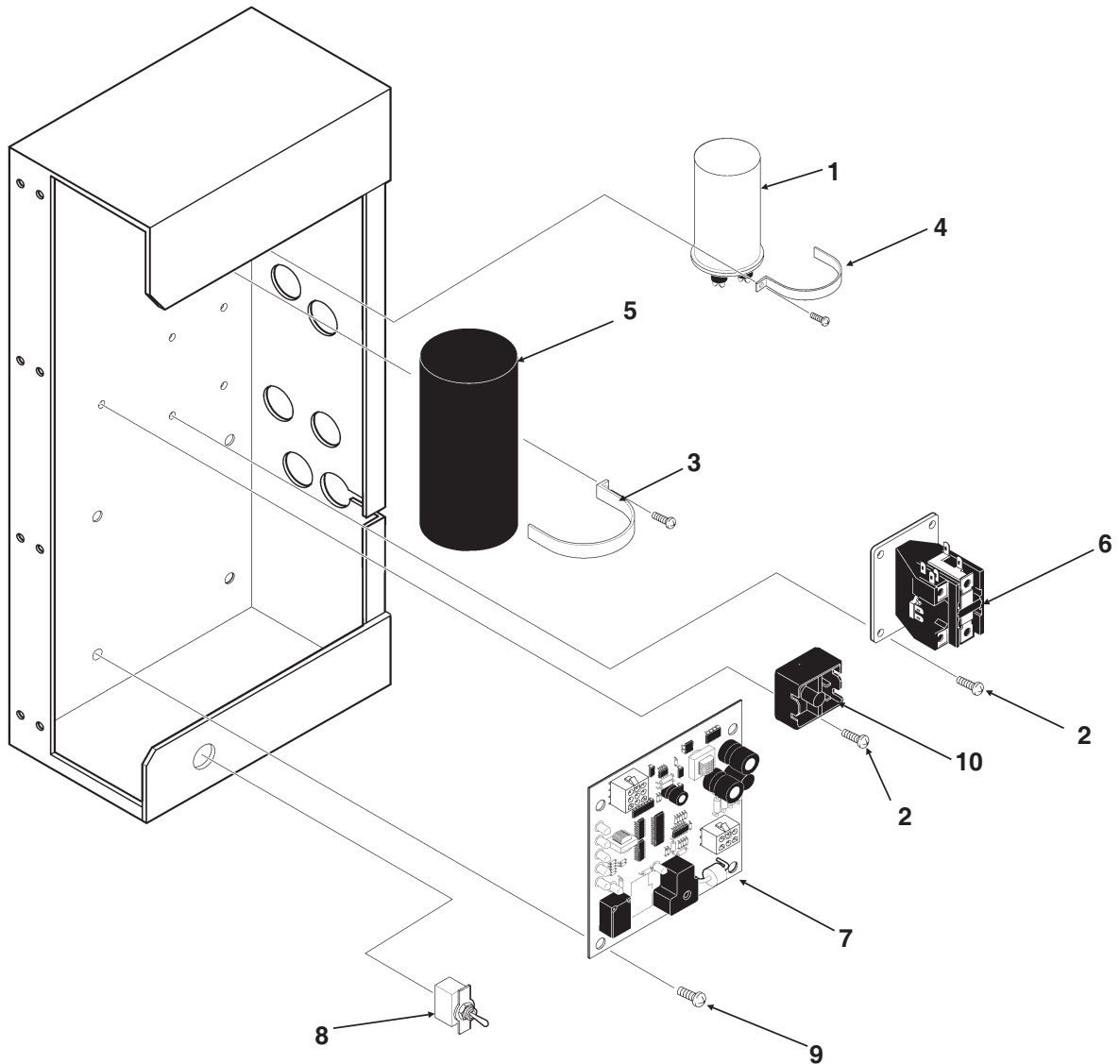

ITEM NUMBER	PART NUMBER	DESCRIPTION
1	18-1901-54	Start Capacitor, 60 Hz
	18-1901-53	Start Capacitor, 50 Hz
2.	03-1638-03	Screw
3.	A35971-002	Run Cap Bracket
4.	A35971-001	Start cap bracket
5.	18-1902-45	Run capacitor, 60 Hz
	18-1902-53	Run capacitor, 50 Hz
6.	12-2469-02	Single Phase Contactor
	12-2533-02	Three phase contactor

Note: Hz means Cycles, 50 Hz is 50 cycle, the model number ends in a -6 for 50 Hz models.

ITEM NUMBER	PART NUMBER	DESCRIPTION
7.	12-2835-21	Circuit Board
8.	12-0426-02	Mode Switch
	NME-6 or FME-6 only: (50 Hz)	
	12-2637-01	Mode Switch
9.	12-2350-01	Standoff
10	18-1903-33	Potential Relay, 60 Hz
	18-1903-54	Potential relay, 50 Hz

NOT ILLUSTRATED

11.	A37861-001	Control Box Cover
12.	12-2745-01	Low voltage harness (9 pin)
		High voltage harness (6 pin)
13	12-2747-01	High voltage harness (6 pin)

NME954 & FME1204 SERVICE PARTS

AIR AND WATER COOLED, 208-230/60/1

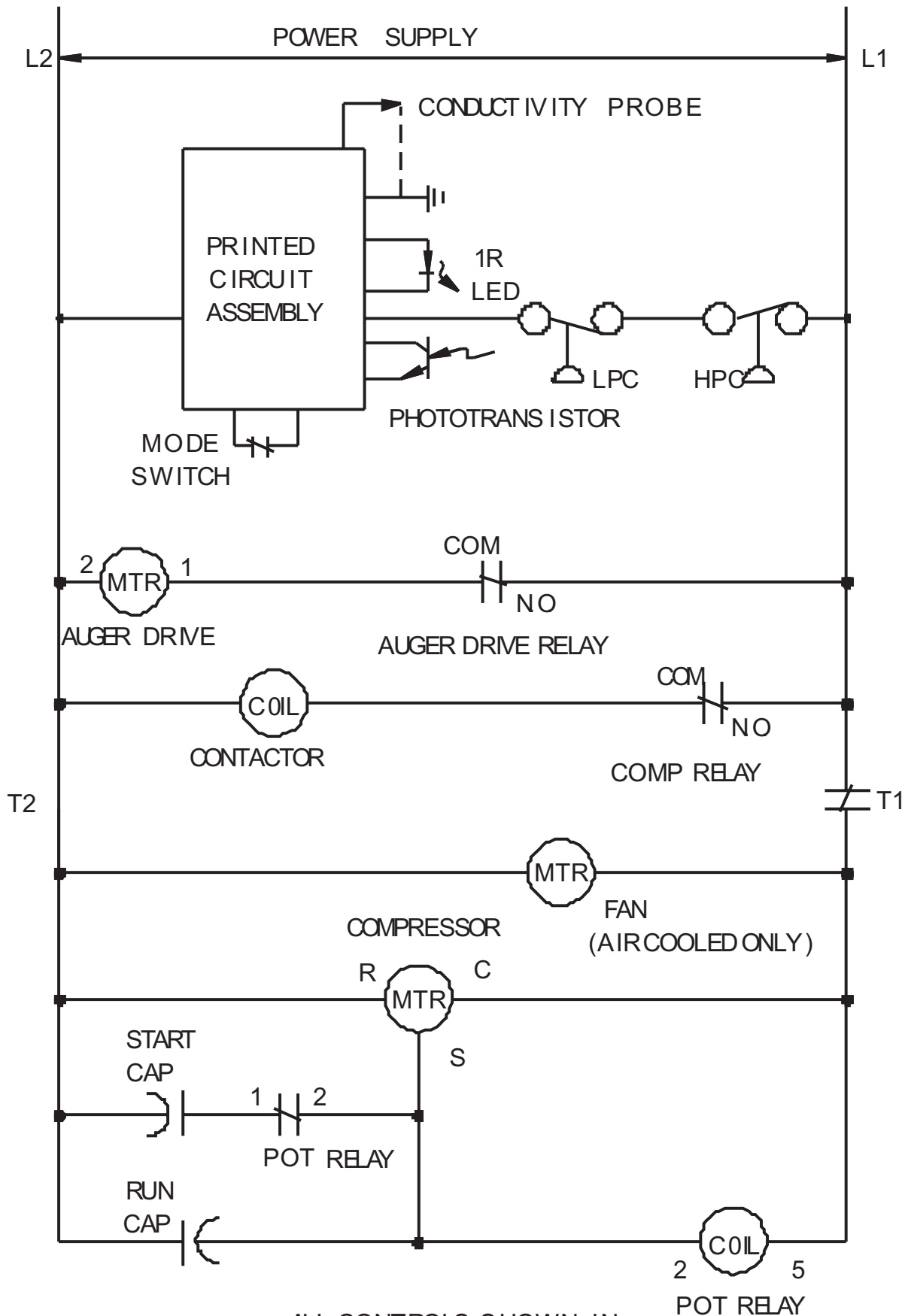

ALL CONTROLS SHOWN IN
ICE MAKING MODE

January 2000

Page 10

NME954 & FME1204 SERVICE PARTS

AIR AND WATER COOLED, 208-230/60/1

7-2678-01

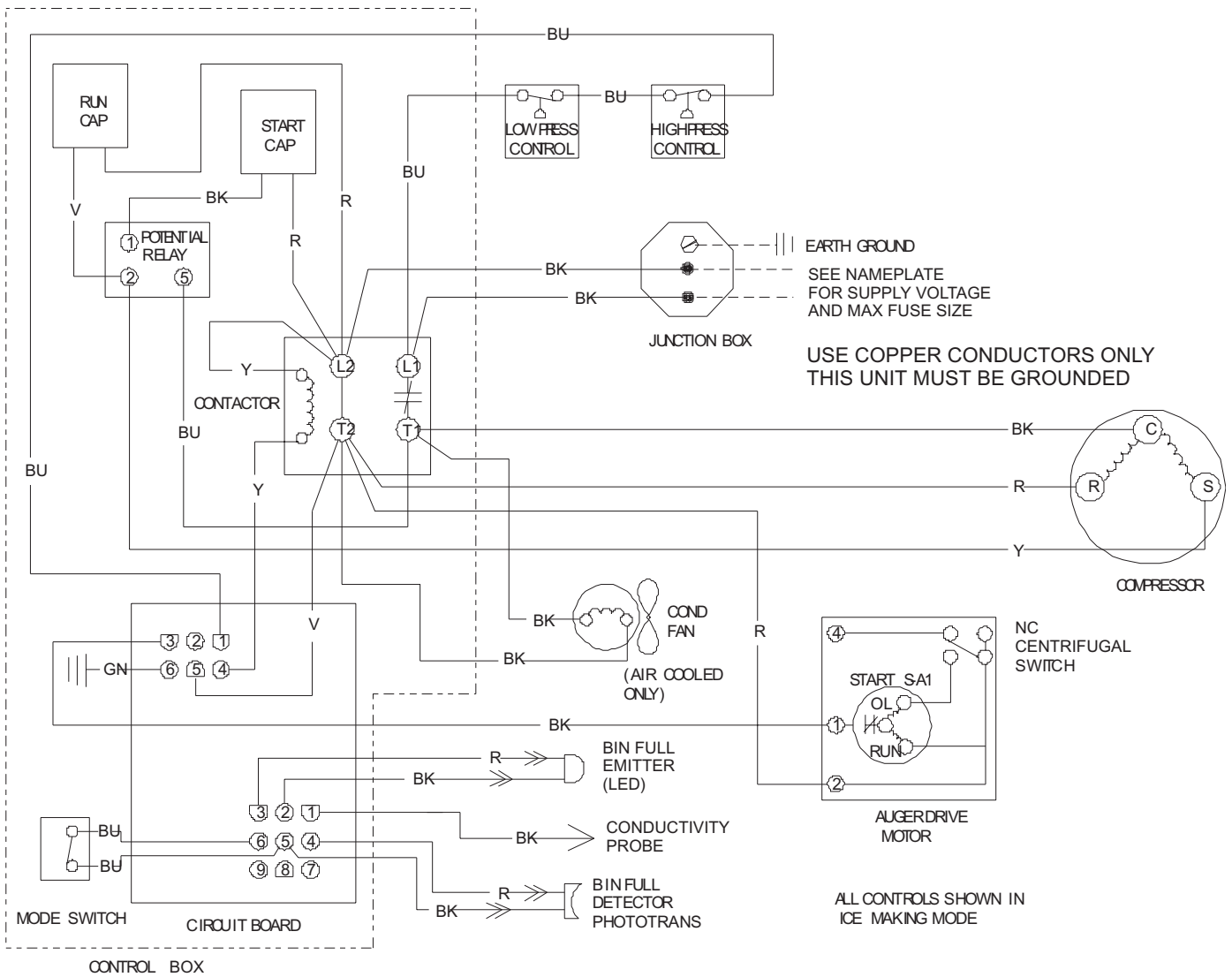

NME954 & FME1204 SERVICE PARTS

AIR AND WATER COOLED, 208-230/60/3

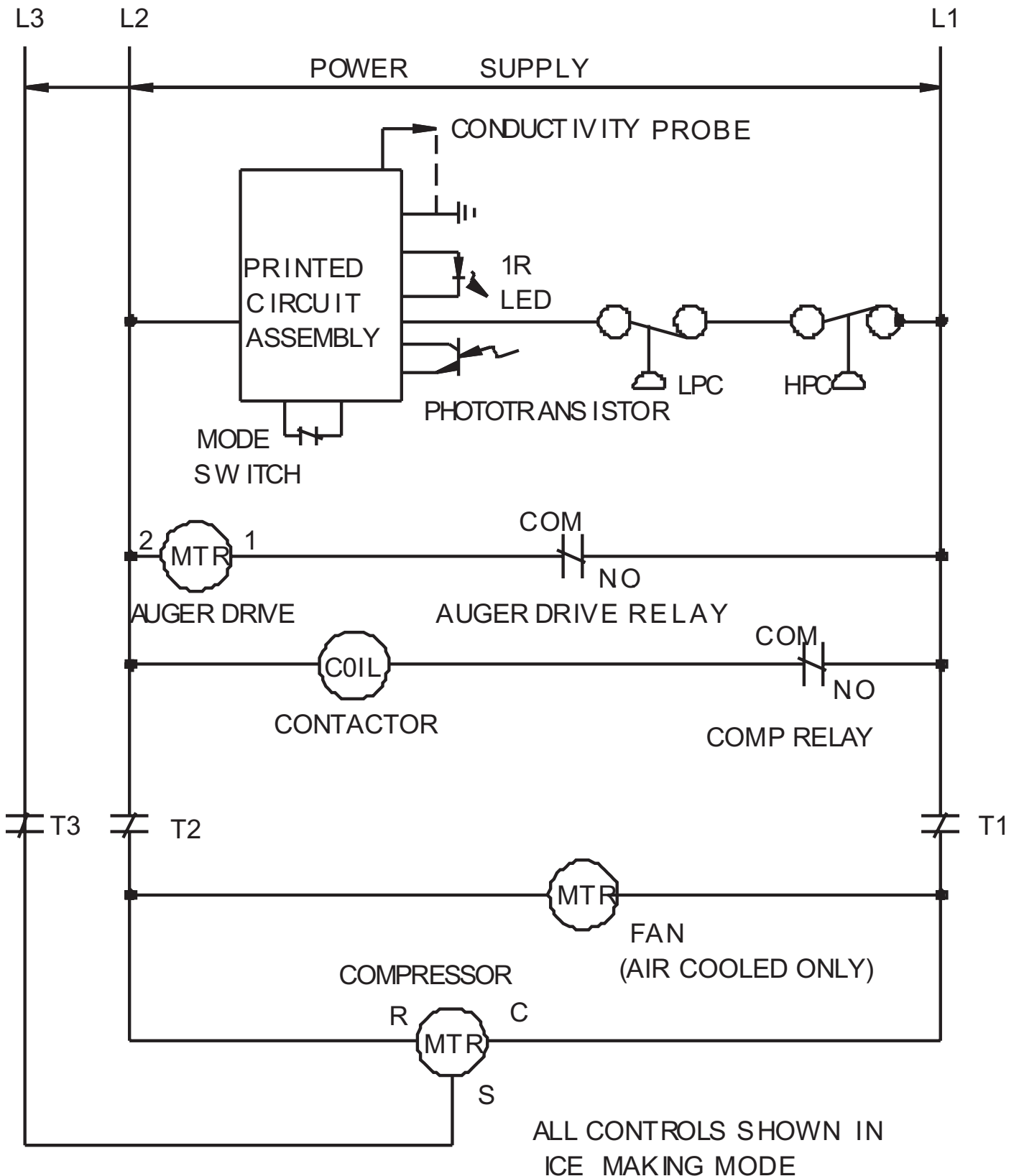

NME954 & FME1204 SERVICE PARTS

AIR AND WATER COOLED, 208-230/60/3

7-2680-01

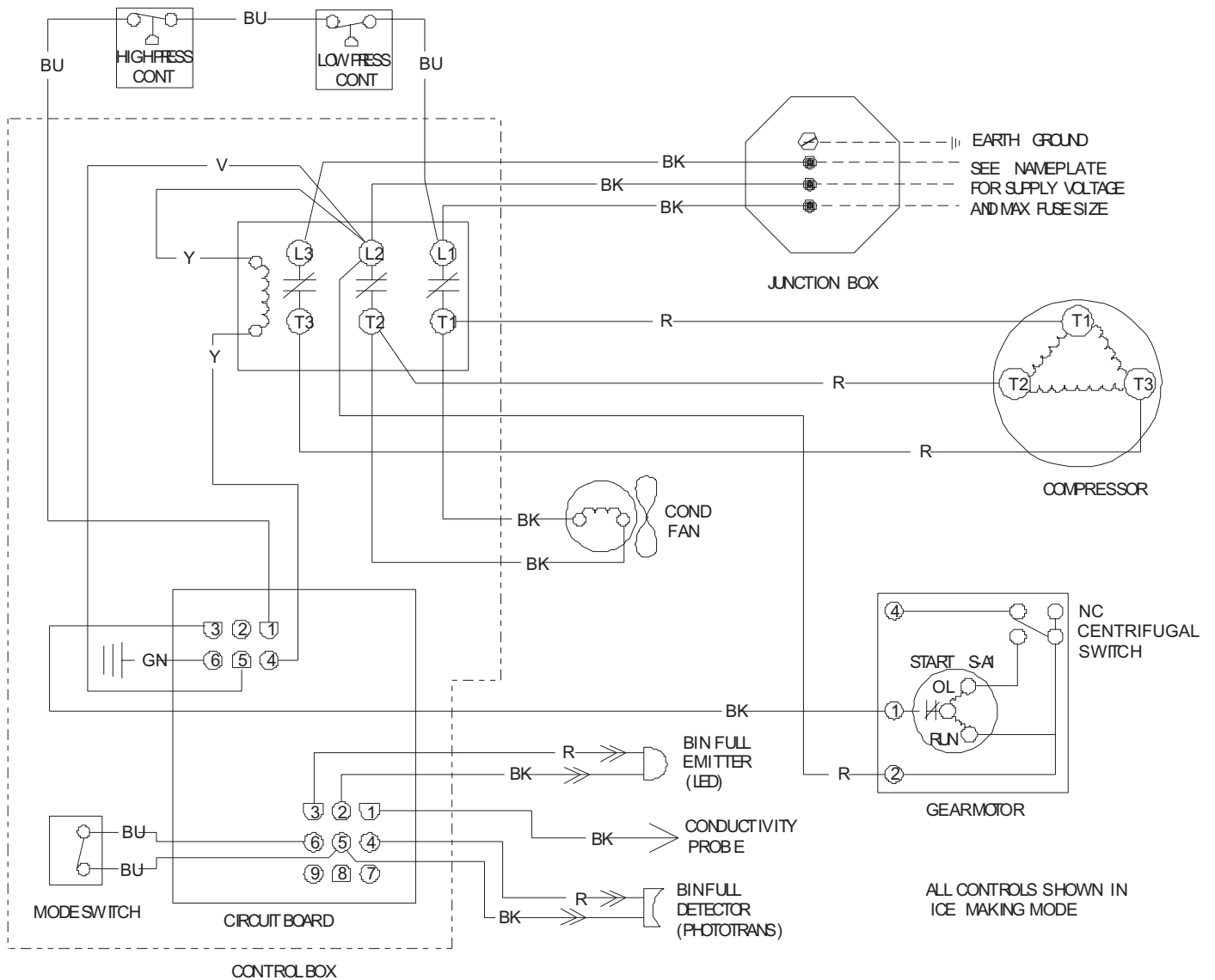

NME954 & FME1204 SERVICE PARTS

NME954 or FME1204 -6

